

EN Installation manual

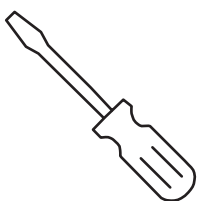
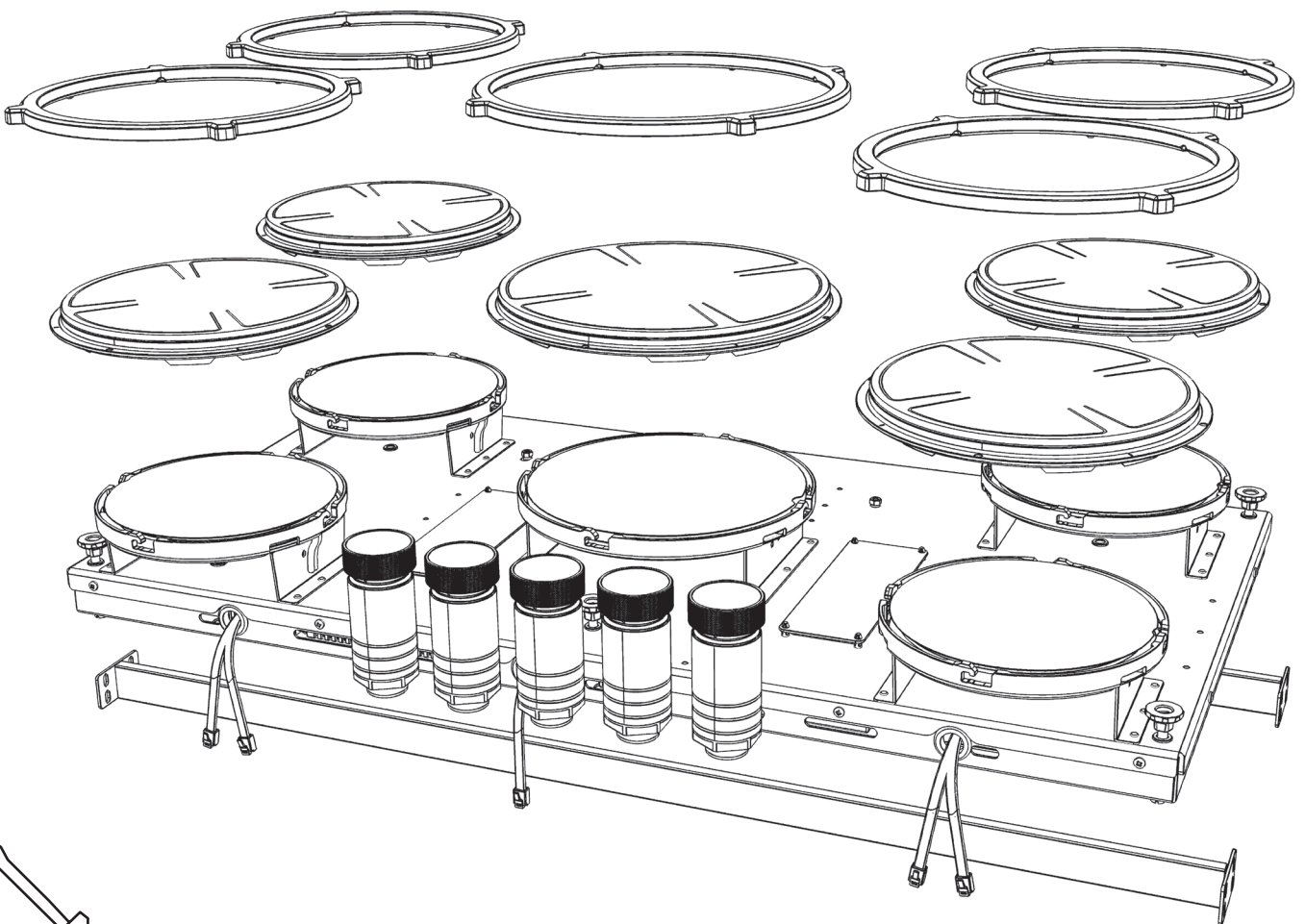

Induction
Top Side/Front Side

Important dimensions

Top Side (TS) hole pattern worktop

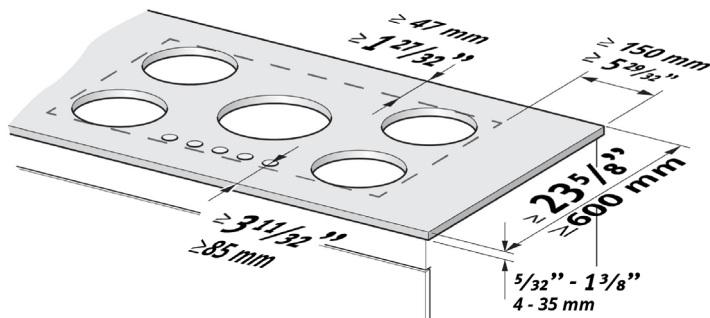

fig. 1

Visit our website for all drawings of the models.

Front Side (FS) hole pattern worktop

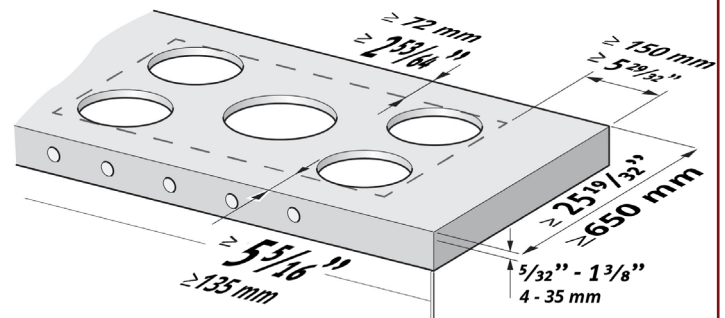

fig. 2

Visit our website for all drawings of the models.

Height induction appliance (TS en FS)

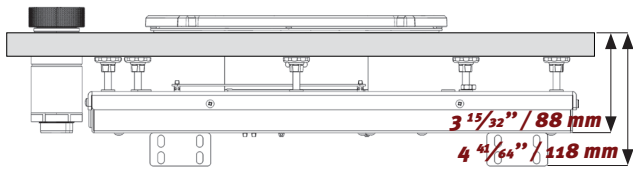

fig. 3

Placement support bar set (Top Side and Front Side)

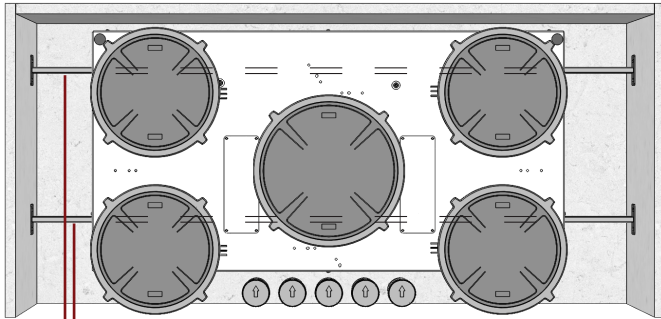

fig. 4

Support bar

*Support bar set contains two support bars.

Extractor hood or kitchen cabinet height (TS and FS).

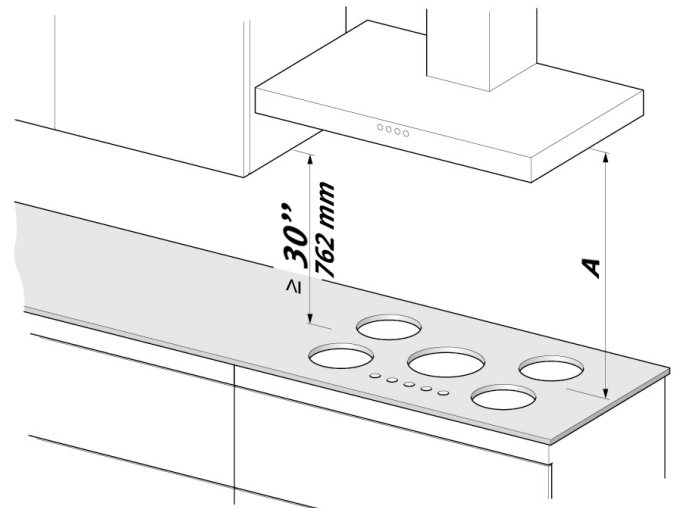

fig. 5

- A PITT Cooking induction appliance should never be mounted over the separation of two cabinets. It has to be accessible in case it needs servicing.
- Keep in mind that the total thickness of the induction appliance and support set is 4 41/64 inch / 118 mm (Top Side and Front Side) measured from the top of the worktop (fig. 3). This is important for constructing the kitchen.
- To prevent bending of the worktop, the induction appliance needs to be supported with the PITT Cooking support bar set (fig. 3 and 4).
- Ensure that there are sufficient ventilation options.
- All mentioned dimensions should always be taken into account and checked before installing the induction appliance (fig. 1, 2 and 5).
- A 30 inch minimum clearance between the top of the cooking surface and the bottom of an unprotected wood or metal cabinet needs to be realised (fig 5).
- **A** = The minimum safety distance specified by the hood manufacturer must be maintained between the cooktop and the hood above it (fig 5). Please refer to the hood's installation instructions for the specific safety clearances.
- **To eliminate the risk of burns or fire by reaching over heated surface units**, cabinet storage space located above the surface units should be avoided. If cabinet storage is to be provided, the risk can be reduced by installing a range hood that project horizontally a minimum of 5 inches / 127 mm of the cabinets.

Warnings and regulations

Electrical connection instructions

- The PITT Cooking induction appliance should only be connected by a licensed installer. To ensure safety and warranty, repairs should only be carried out by authorized professionals. You should only use original spare parts.
- The induction appliance must be connected to the power supply by a licensed electrician.
- The connection data shown on the rating plate must correspond to the values of the power supply. If in doubt, consult a licensed electrician.
- Never connect the induction appliance with power strips. It is prohibited to connect the appliance by means of a power-supply cord kit.
- During installation, maintenance and repair work, the appliance must be completely disconnected from the power supply. To do this, proceed as follows:
 - o switch off the fuses in your fuse box, or
 - o turn the fuses in your fuse box completely out, or
 - o disconnect the power cord from the outlet
- If the cooktop is connected without a plug, it is mandatory to provide a switch (or similar) in the fixed wiring. This ensures that the appliance can be disconnected from the power supply if necessary.
- A power cord from an electronic device must not come into contact with the cooking zones. The insulation of the connecting cable may be damaged by heat.

Technical safety instructions

- The right to warranty is immediately voided if the induction appliance is repaired by an unauthorized person.
- A damaged induction appliance may endanger your safety.
- Do not use the induction appliance when it is damaged. In case it's damaged, it must be repaired by an authorized person. For this reason, check the product regularly for damage.
- The electrical safety of the cooktop is only guaranteed if it is connected according to local regulations. If in doubt, have the electrical installation inspected by a licensed professional.
- Only use the cooktop when it has been installed and fitted according to the instructions.
- It is dangerous to the user to touch live parts. This can also result in the appliance not functioning properly.
- Defective parts must only be replaced with original PITT Cooking parts.
- The cooktop must not be used with an external timer or remote system.
- If the power cord is damaged, it must be replaced by an authorized electrician and the new power cord must meet all requirements.
- Ensure that all product parts are positioned as indicated.
- Ensure adequate ventilation during use. If a drawer is located under the cooktop, there should be sufficient space under it.
- The cooktop is not suitable for use at altitudes above 2000 meters (calculated from sea level).
- The system must be installed in a dry, frost-free area.

Note: The PITT Cooking induction appliance may only be used on worktops made of: Ceramic, porcelain, quartz, concrete, glass, natural stone, marble, or similar materials, provided they are protected against hygroscopic influences and are **non-conductive**.

The worktop thickness must be between $\frac{5}{32}$ inch / 4 mm and $1 \frac{3}{8}$ inch / 35 mm.

Assortment

Assortment induction

See below the complete assortment of induction. Every model is compatible with the Top Side and Front Side configuration. Only the Top Side configuration is shown below.

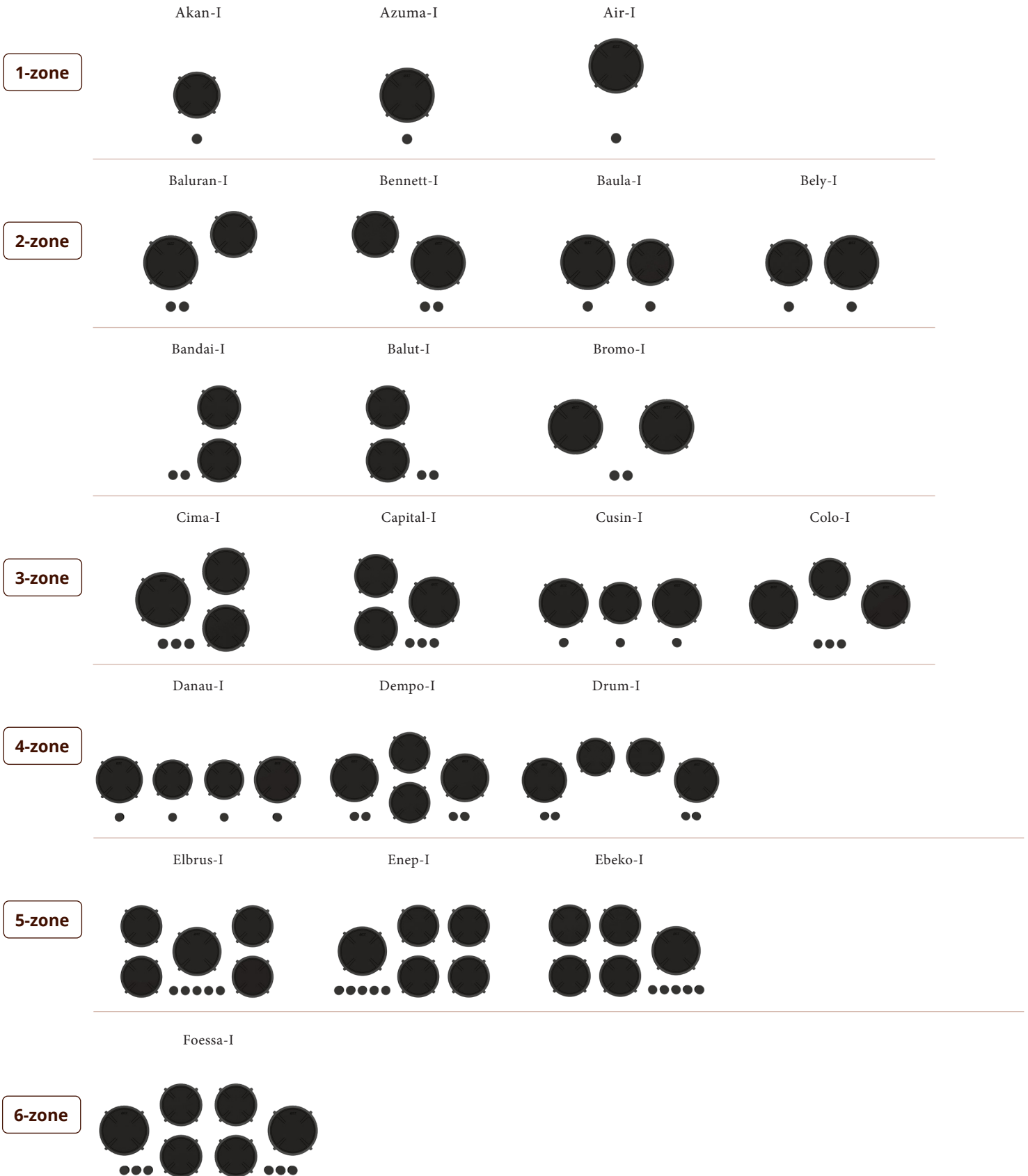

Overview of packaging contents

Below, you can find the packaging contents. There may be different numbers of parts present in your package. See below a list for the part numbers.

	Akan-I	Azuma-I / Air-I	Baula-I / Bely-I / Baluran-I / Bennett-I	Bandai-I / Balut-I	Bromo-I	Capital-I / Cima-I	Cusin-I / Colo-I	Danau-I / Dempo-I / Drum-I	Ebeko-I / Elbrus-I / Enep-I	Foessa-I
Small Decorative ring	1	-	1	2	-	2	1	2	4	4
Large Decorative ring	-	1	1	-	2	1	2	2	1	2
Small induction zone	1	-	1	2	-	2	1	2	4	4
Large induction zone	-	1	1	-	2	1	2	2	1	2
Control knob	1	1	2	2	2	3	3	4	5	6
Cables for control knob	1	1	2	2	2	3	3	4	5	6
Support bar set	1	1	1	1	1	1	1	1	1	1

**Before starting with the installation, please check if all parts are included in the packaging.
If a part is missing or damaged, please contact the service department.
Contact details can be found on the back of the manual.**

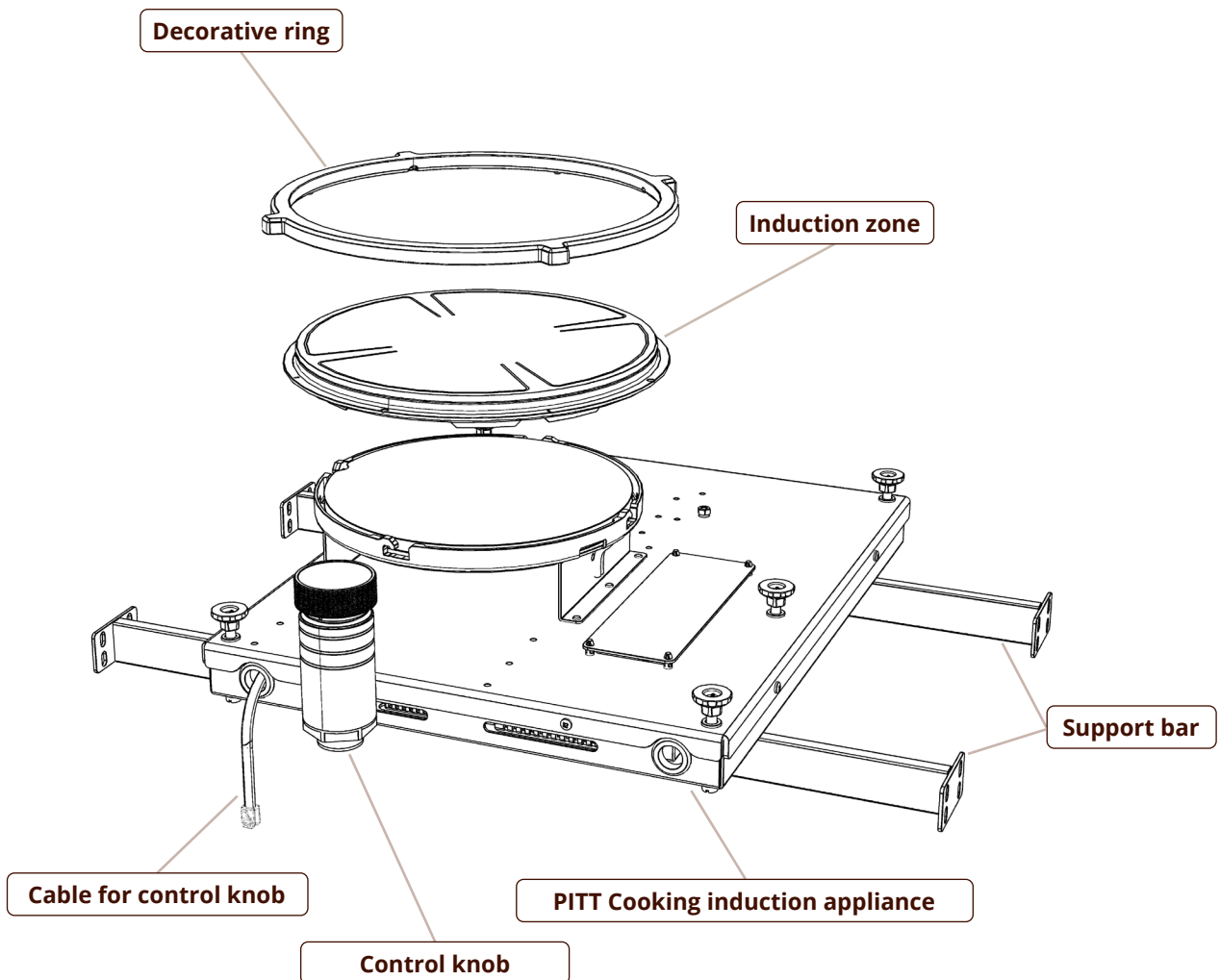

*The example of this package content is the model Azuma-I.

1. Preparing the induction appliance for installation

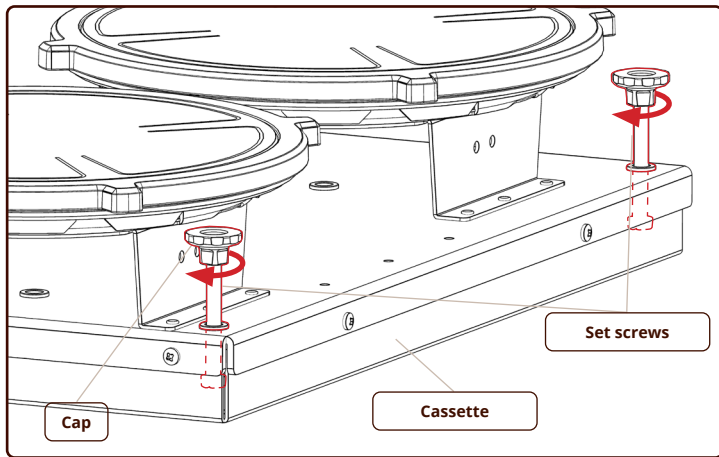

Step 1

Check if all set screws have a cap present. After the check, loosen **all the set screws** until the caps touch the cassette.

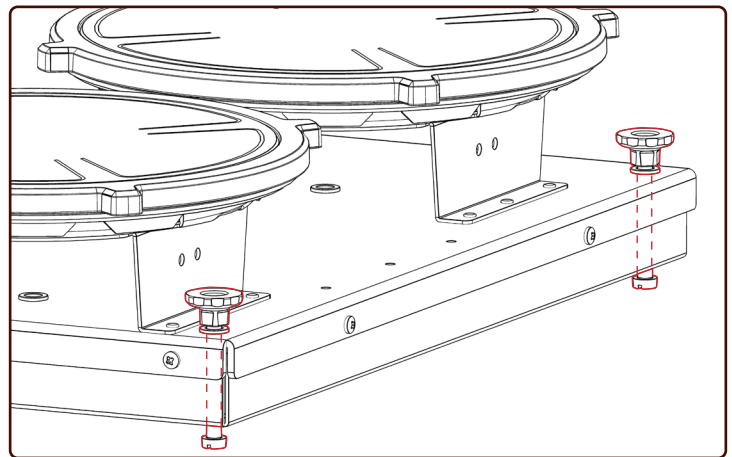

Step 2

Locate all set screws and repeat Step 1 for **all the set screws**.

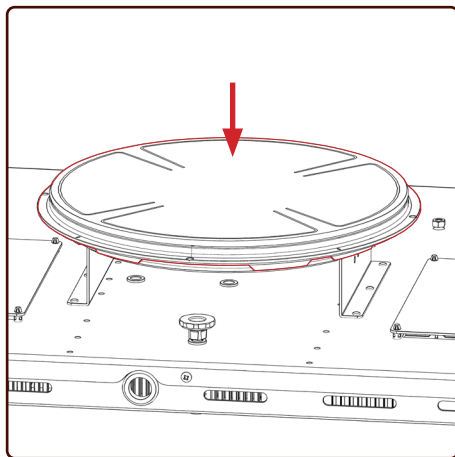

Step 3

Push the induction zone downwards.

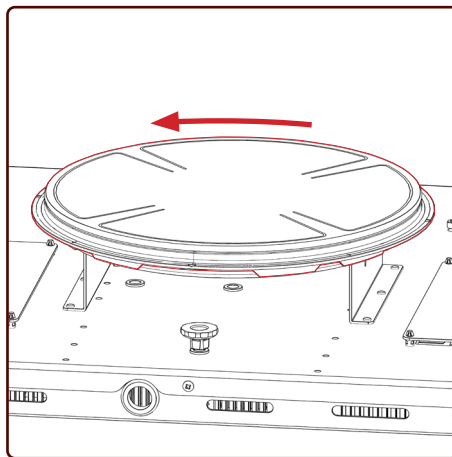

Step 4

Turn the induction zone counterclockwise.

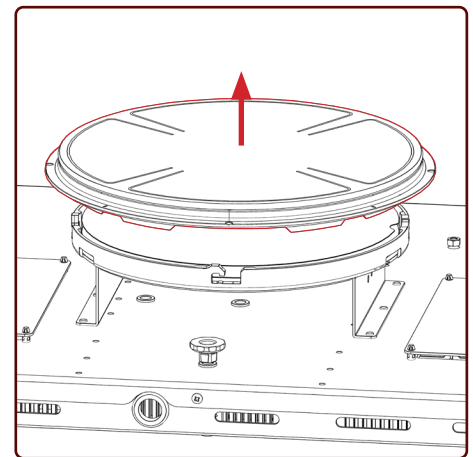

Step 5

Lift all the induction zones off the appliance and lay them carefully away.

2. Installing the induction appliance into the countertop

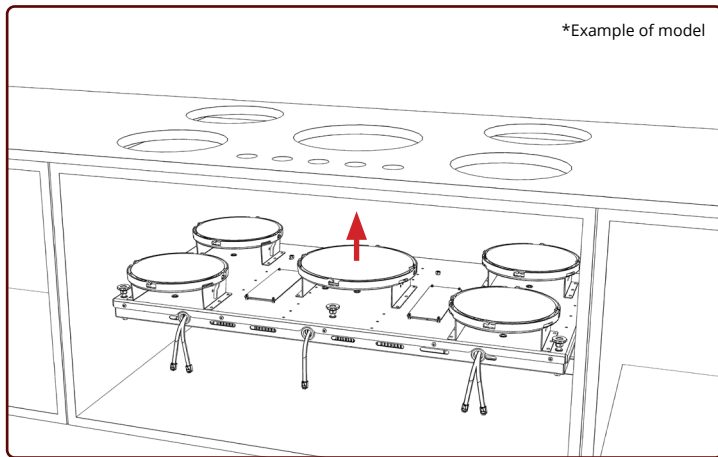

Step 6

Position the induction appliance in the hole pattern of the countertop.

The induction appliance can be heavy. It is recommended that at least two people perform this Step.

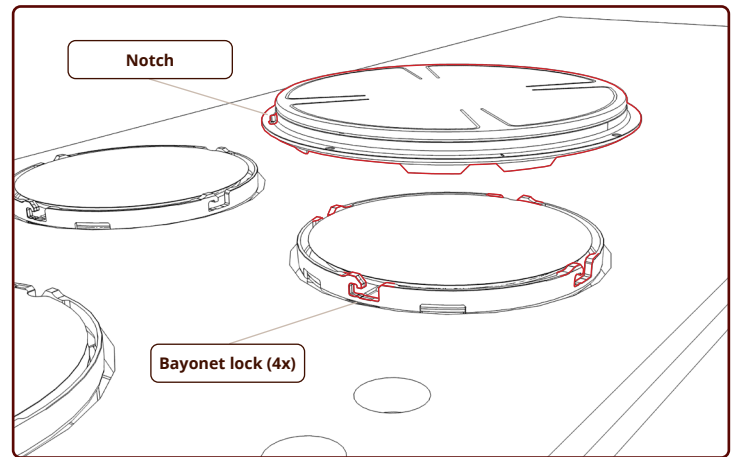

Step 7

In preparation of the next steps: make sure that the **notch** on top of the induction zone is always positioned at the **upper left corner**.

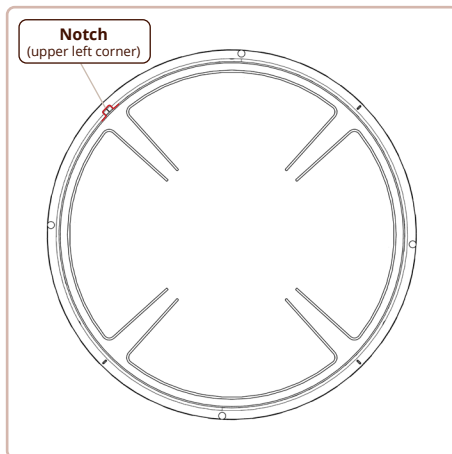

Information

Make sure that the induction zone is positioned correctly and that the **notch** is at the **upper left corner**.



WARNING

It's very important for the safety of the installer and customer that the induction zones are correctly installed.

Make sure that all of the bayonet locks are correctly assembled on every induction zone.

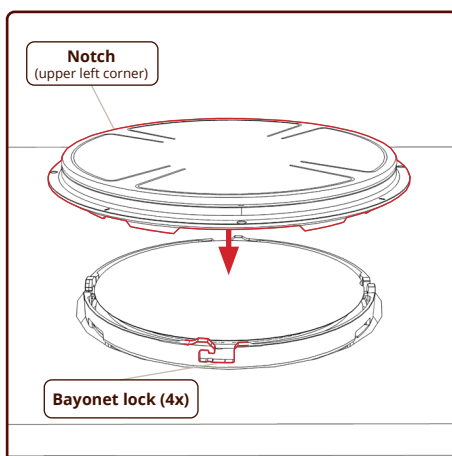

Step 8

Make sure that the induction zone is positioned correctly and that the **notch** is at the **upper left corner**.

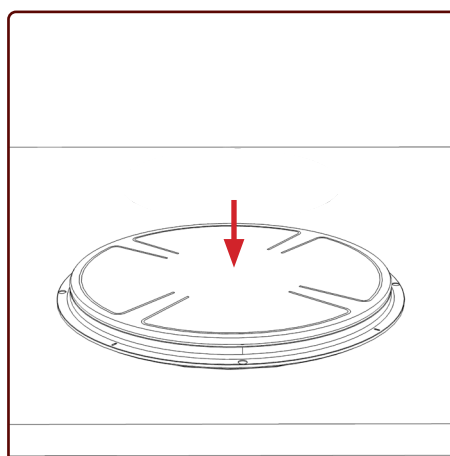

Step 9

Move the induction zone carefully downwards.

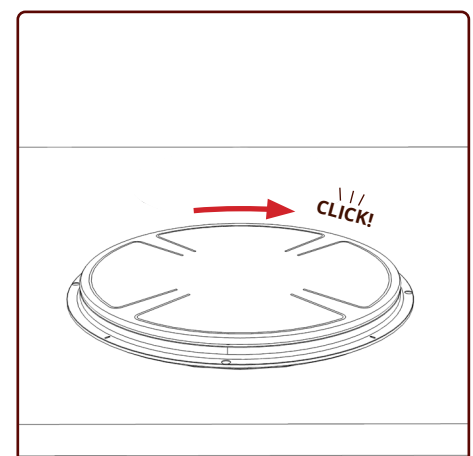

Step 10

Lock the induction zone by turning it clockwise. Perform Step 8 to 10 for all induction zones.

3. Making the induction appliance waterproof

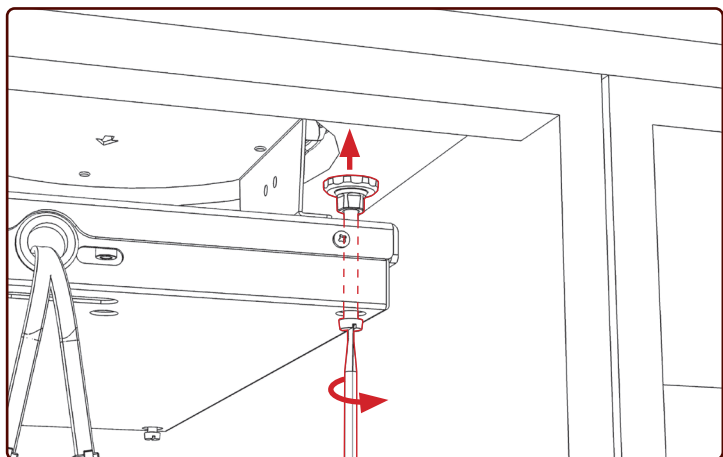

Step 11

Tighten all the set screws **hand-tight**. Don't overtighten the set screws. Read the next Steps thoroughly.

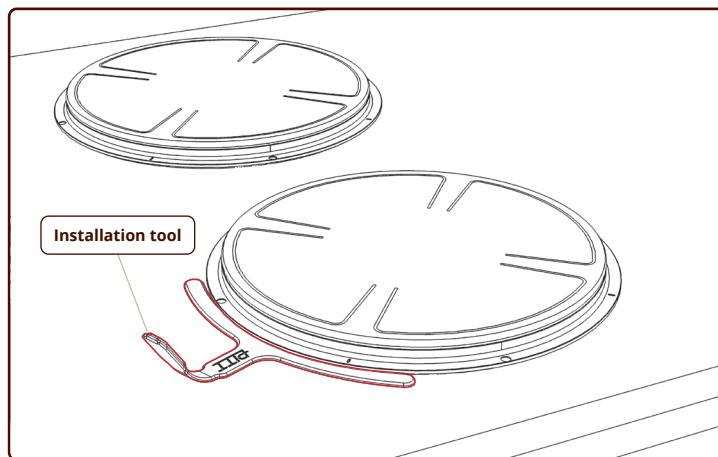

Step 12

Use the provided installation tool during tightening of the set screws. The installation tool shows the correct height of the induction zone(s).

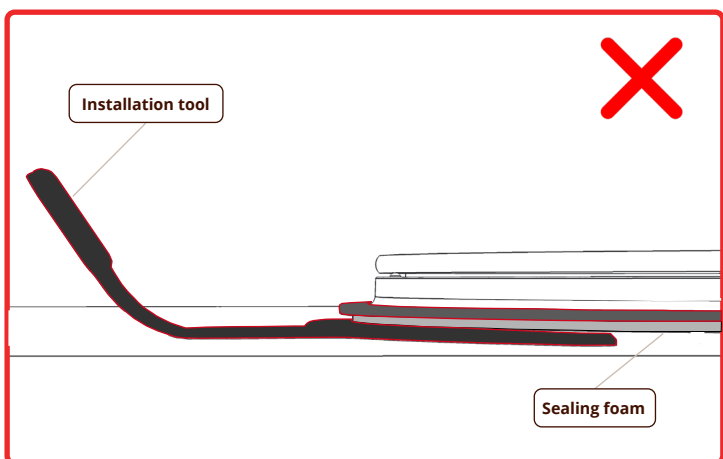

Attention

The induction zone is too high and the sealing won't be waterproof. Make sure to tighten the set screws more, so the induction zone will be at the same height of the installation tool.

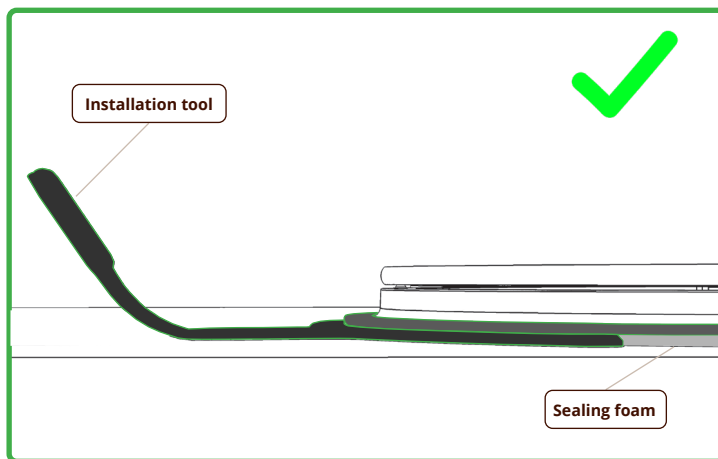

Attention

The set screws are correctly tightened and the sealing of the induction zone is waterproof.

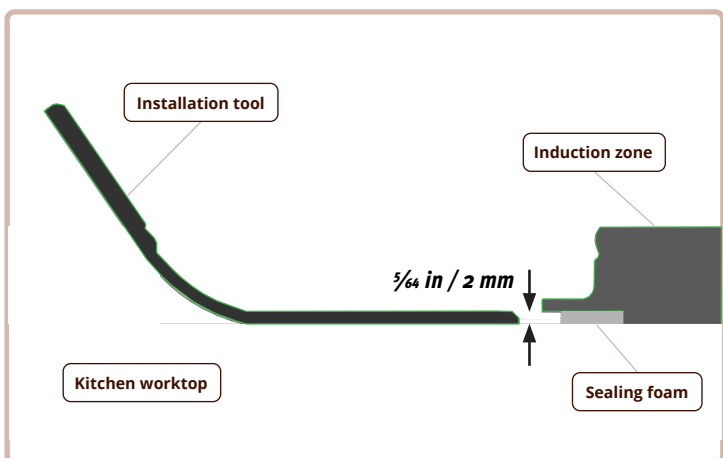

Attention

The distance between the underside of the induction zone and kitchen worktop must be $\frac{5}{64}$ in / 2 mm.



It's very important to make sure that the induction zones are installed at the correct height. This can be done by correctly tightening the set screws.

If these steps are not followed properly, the induction appliance is not waterproof.

4. Installing the control knobs (1/2)

Top Side

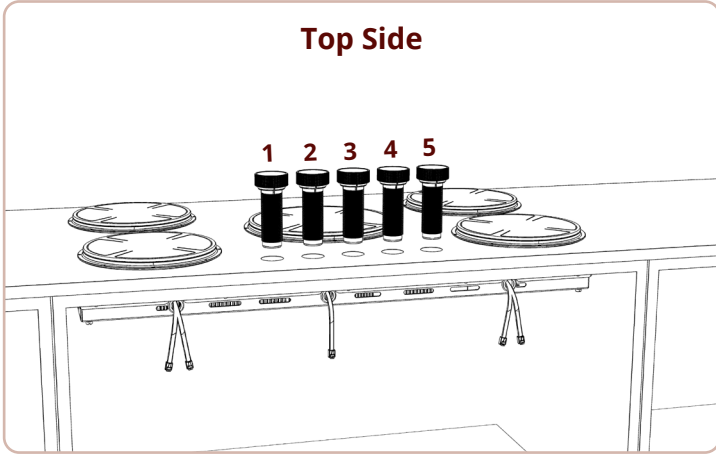

Information

When installing a Top Side model, install the control knobs **on top of the countertop**. The control knobs are numbered at the underside.

Front Side

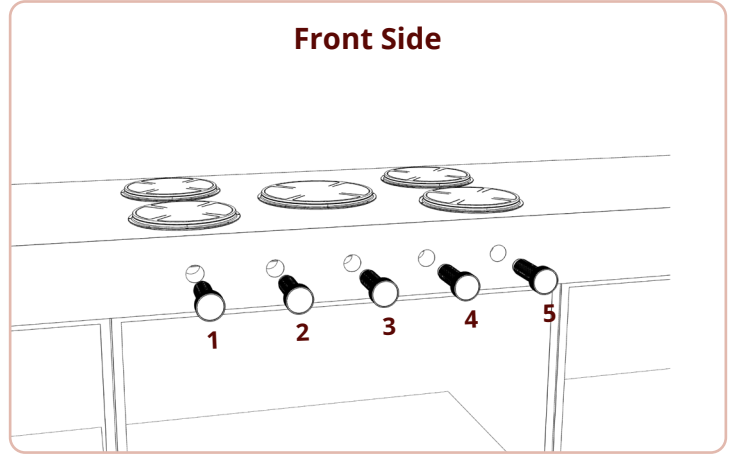

Information

When installing a Front Side model, install the control knobs **on the front of the countertop**. The control knobs are numbered at the underside.

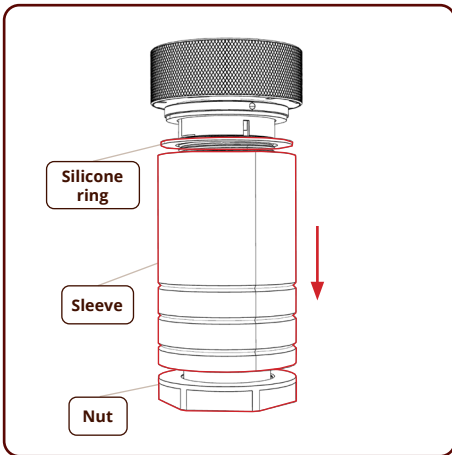

Step 13

Disassemble the nut, sleeve and silicone ring from the control knob.

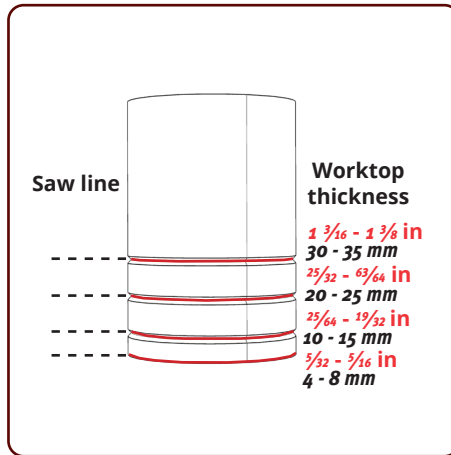

Step 14

Cut the sleeve to the correct length. The sleeve must be cut to the length corresponding to the **thickness of the worktop**.

Worktop thickness

- $1 \frac{3}{16} - 1 \frac{3}{8}$ in
- 30 - 35 mm
- $2 \frac{5}{32} - \frac{63}{64}$ in
- 20 - 25 mm
- $2 \frac{5}{64} - 1 \frac{1}{32}$ in
- 10 - 15 mm
- $\frac{5}{32} - \frac{5}{16}$ in
- 4 - 8 mm

Exploded view

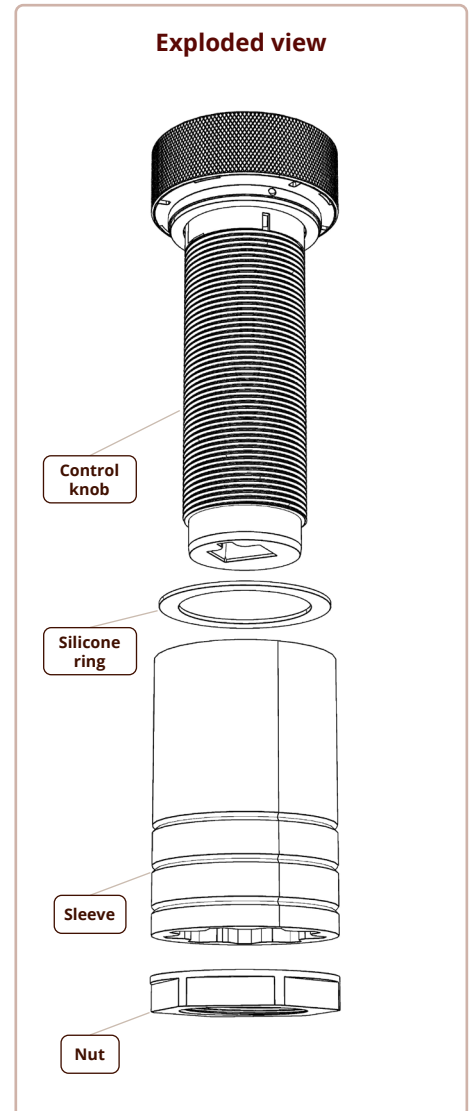

Information

Exploded view of the control knob.



Cut the sleeve to the correct length for safety purposes!

The aluminum thread of the control knob must not be visible when installing the sleeve at Step 16.

4. Installing the control knobs (2/2)

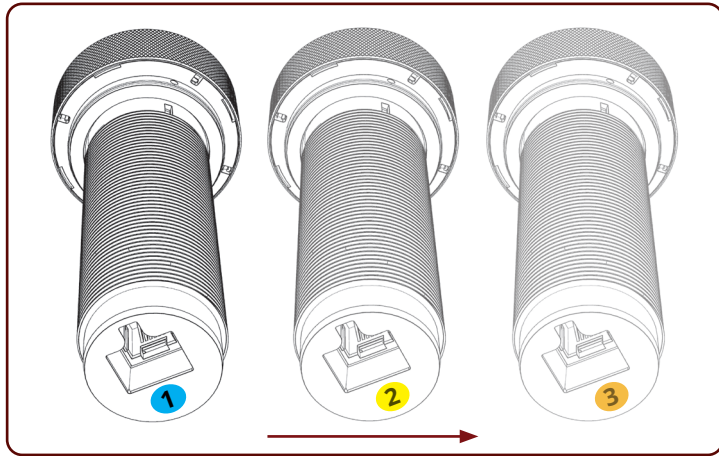

Step 15

Note the sticker at the underside of the control knob(s). **The leftmost control knob starts with 1 and it adds up to the right side.**

The image shows a representation of the stickers on the underside of the control knobs. There could be 1 to 6 control knobs in total.

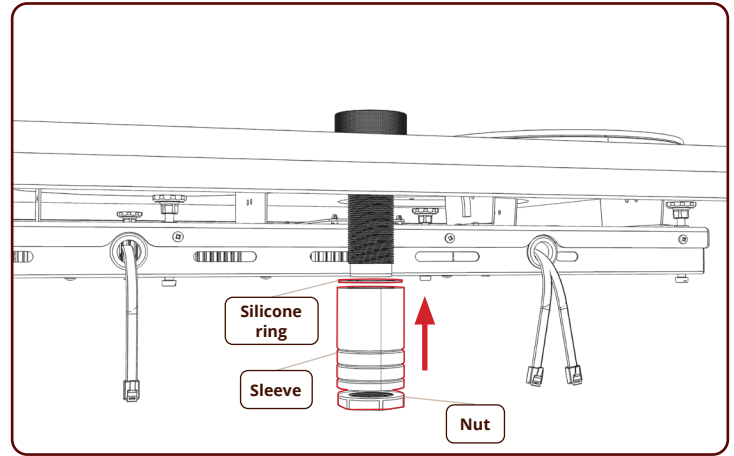

Step 16

Insert the control knob(s) in the hole pattern provided for the control knob(s). Assemble the silicone ring, (cut) sleeve and nut in the correct order.

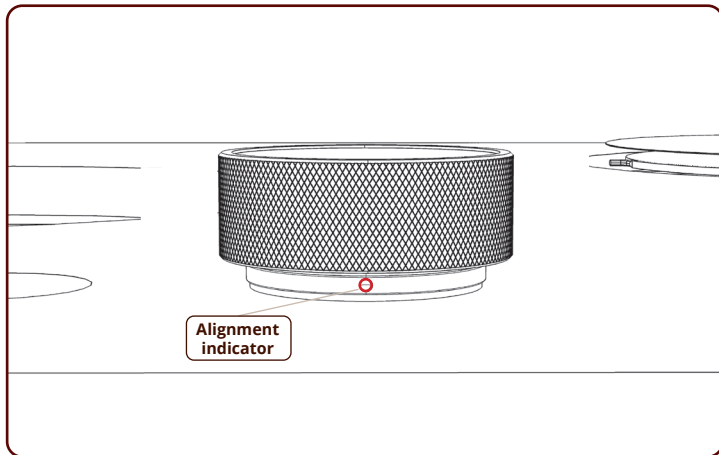

Step 17

Make sure the alignment indicator is facing the front (Top Side) or facing the top (Front Side). **Firmly tighten the nut of the control knob.**

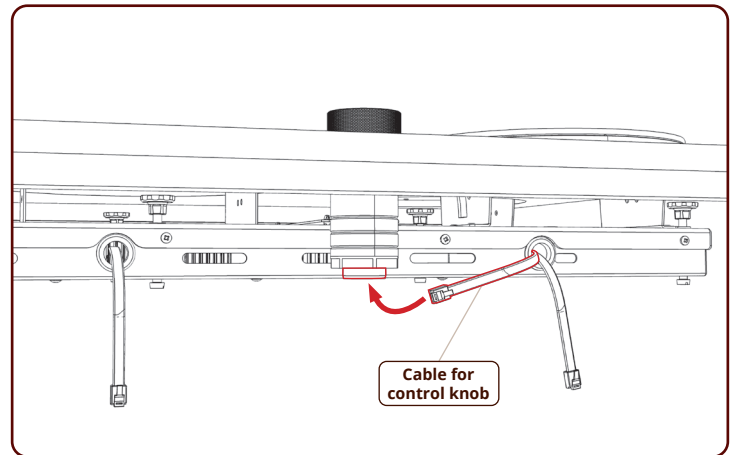

Step 18

Insert the cable for control knob in the connection hole of the control knob. If there is more than one control knob, repeat this step till every control knob is connected.

Make sure the nut is properly tightened.

If this isn't done, the control knob may loosen and become unusable for the user.

5. Connect the induction appliance to the power supply (1/2)



The induction appliance is equipped with a power cord enclosed in a flexible metal conduit, with a length of 3 ft 11 in (1200 mm) and a diameter of 3/4 in (19 mm).

The appliance should only be connected by a licensed installer.

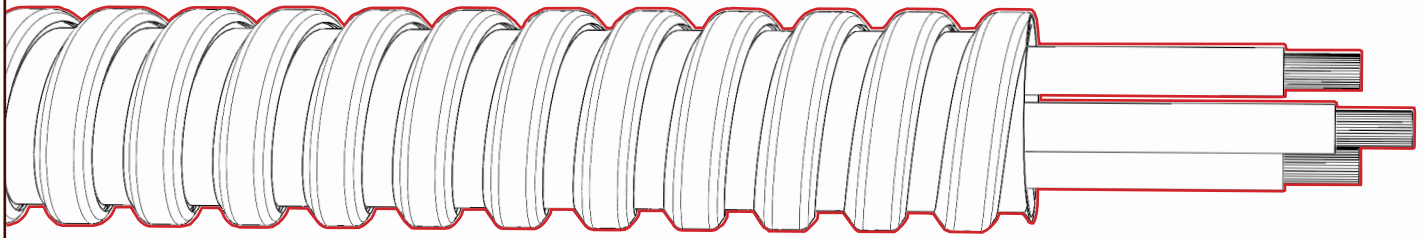

Nameplate label* example

		PITT cooking Darnzig 54 3454 PS De Meern info@pittcooking.com
Made in Holland		
System Specifications 208 - 240 VAC 50-60 Hz 16 A per fase	Specifications Generators Generator 1: 208-240 VAC / 2x16 A / 50-60 Hz Generator 2: 208-240 VAC / 1x16 A / 50-60 Hz	
Country: USA-CAN Model: Elbrus-I Type: Induction	Max. Power: 10.680 W Serialnr.: xxxxxxxxxxxx Articlennr.: 150.00.00.015	
Tested: <input checked="" type="checkbox"/> Date: _____ Signature: _____	HMI: v1.0 BTN: v27 PITT: v19	

**Located on the underside of the appliance*

Akan-I

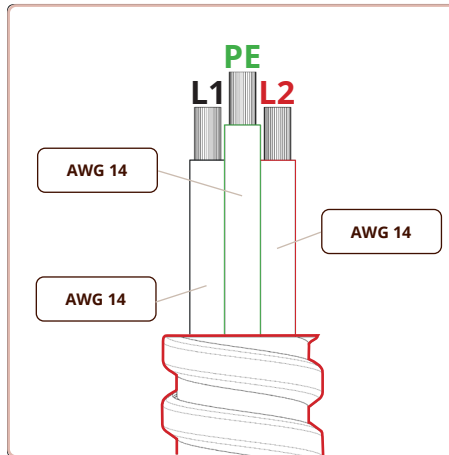

Wiring diagram
208 - 240 V ~
Max. 2.100 Watt

Azuma-I/ Air-I

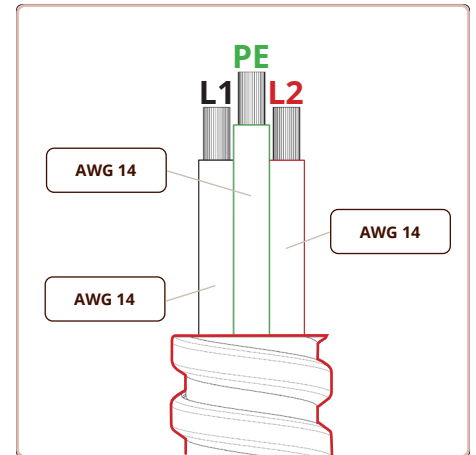

Wiring diagram
208 - 240 V ~
Max. 3.000 Watt

Baula-I/ Bely-I/ Baluran-I Bennett-I/ Bandai-I/ Balut-I

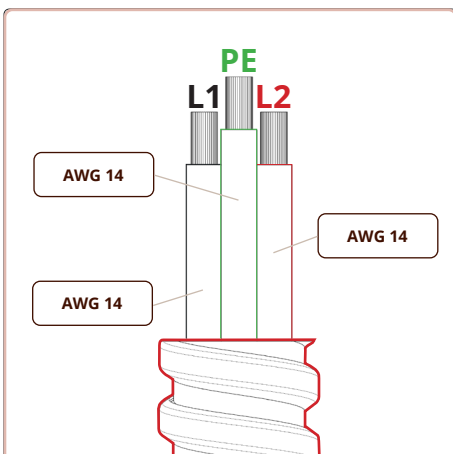

Wiring diagram
208 - 240 V ~
Max. 3.840 Watt

Cusin-I/ Colo-I

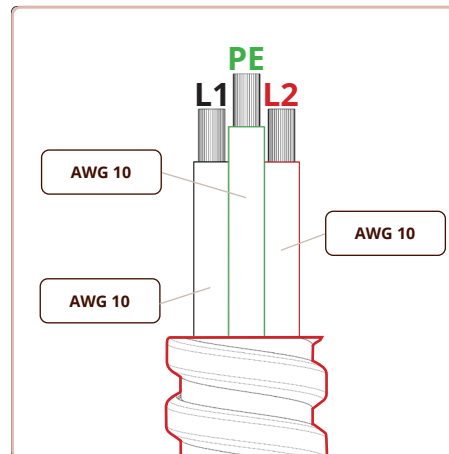

Wiring diagram
208 - 240 V ~
Max. 6.840 Watt

Danau-I/ Dempo-I Drum-I

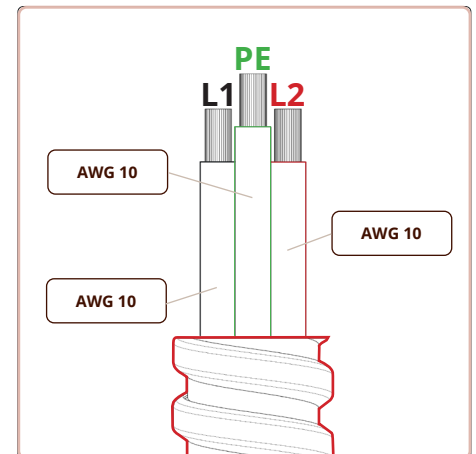

Wiring diagram
208 - 240 V ~
Max. 7.680 Watt

5. Connect the induction appliance to the power supply (2/2)

Bromo-I

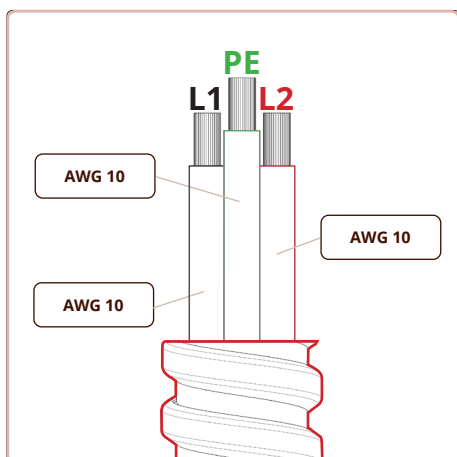

Wiring diagram
208 - 240 V ~
Max. 6.000 Watt

Capital-I/
Cima-I

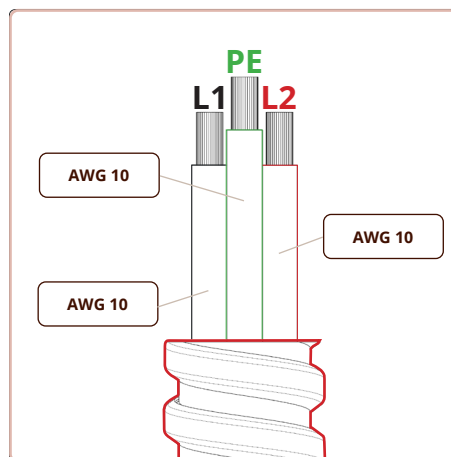

Wiring diagram
208 - 240 V ~
Max. 6.840 Watt

Ebeko-I/ Elbrus-I
Enep-I

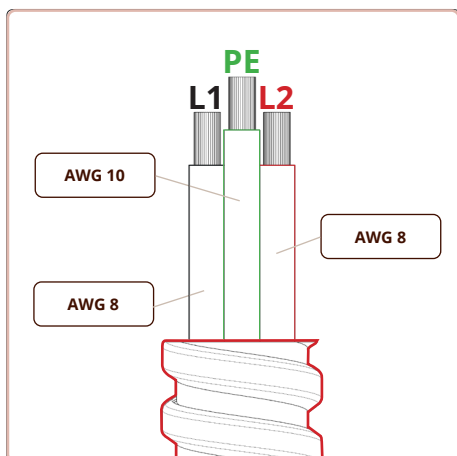

Wiring diagram
208 - 240 V ~
Max. 10.680 Watt

Foessa-I

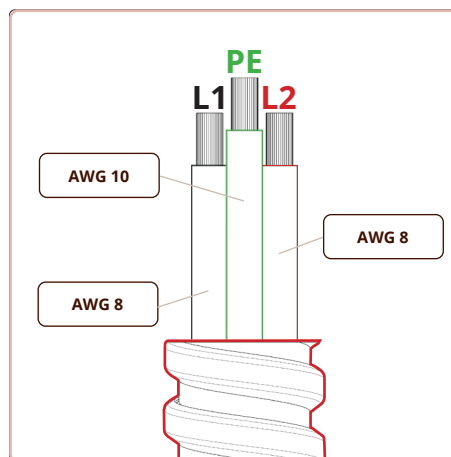

Wiring diagram
208 - 240 V ~
Max. 11.520 Watt

Solutions for possible error codes after the first startup



'Ep1 - buttons'

Double check all connections of the cables to the control knobs and make sure they are properly connected in the control knobs (Step 18).



'Ep3 - LIN' or 'Er - 0x33'

Check the main connection at the underside of the generator (Step 21) and make sure **all connection bridges and wires** are correctly installed.

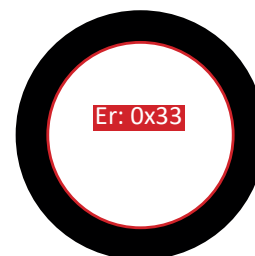

6. Setting up the induction appliance with custom settings

Warning

The user and installer menu must only be operated by a certified installer.

The configuration menu can be accessed by following the next Steps:

1. Switch off the induction appliance. This can be done in two ways:
 - Disconnect the induction appliance from the power supply. Then connect the induction appliance again.
 - When there all the cooking zones are displayed "cold" on the control knobs, the appliance will automatically turn off.
2. When the induction appliance is off, press one of the control knobs.
3. When the logo appears, directly press and hold the leftmost knob (knob 1) for eight seconds.
4. Navigate the menu by rotating to choose the various options. Press the control knob upon confirmation.

If unclear and/or have questions, see the last page of this manual for service contact information.

User menu

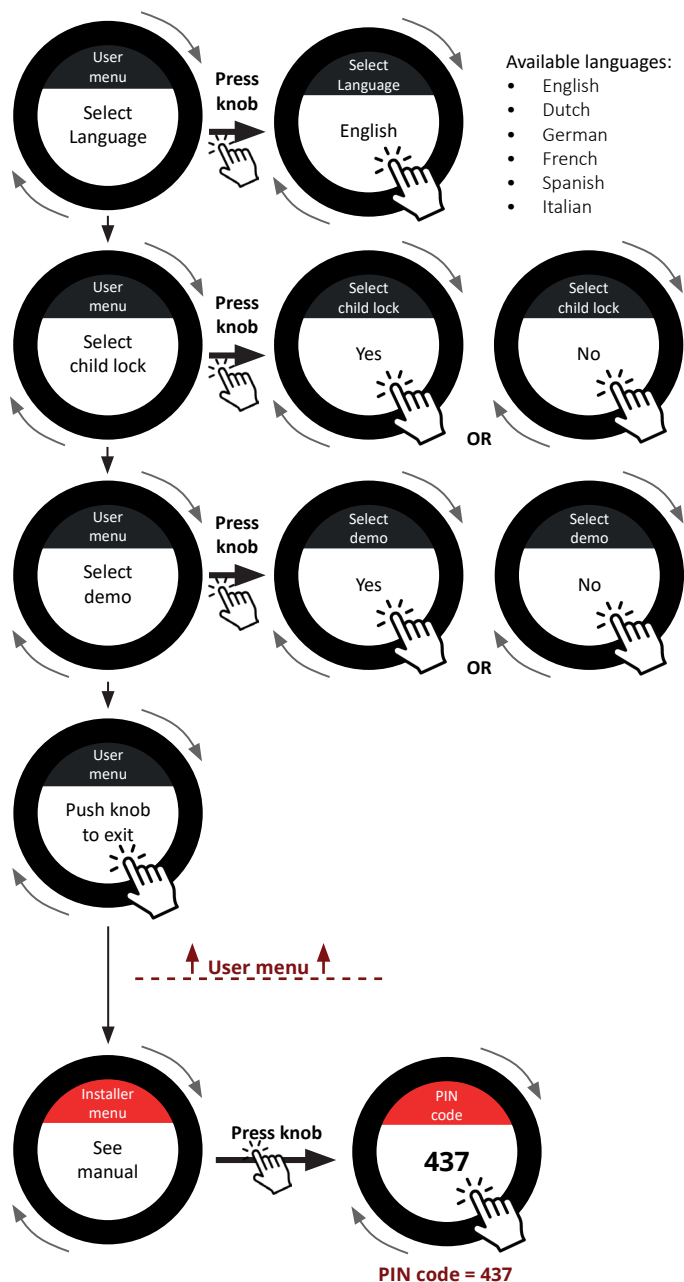

Installer menu

The installer menu must only be operated by an authorized installer.

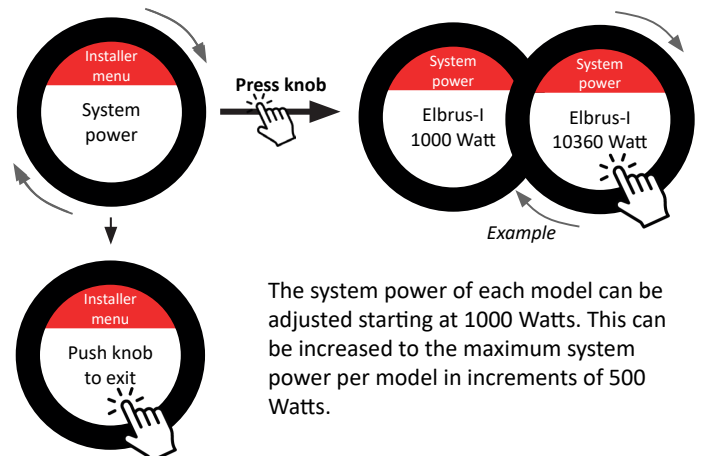

IMPORTANT

Make sure the system power is set correctly.

Don't forget to look at the final checks on the last page!

7. Installing the support bar set

Please follow the installation steps outlined in the one-pager, included with the installation materials.

PITT Cooking - Supportbar

Step 1: Collect the supportbar coponents.

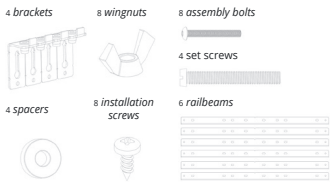

Step 2: Prepare the configurations.

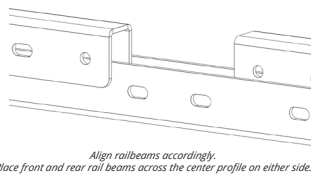

Step 6: Determine the bracket height.

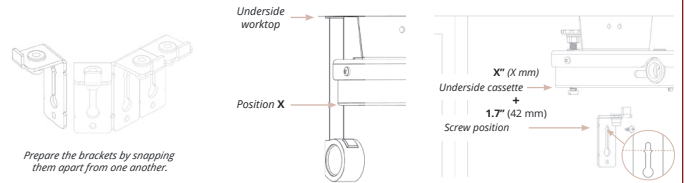

The configuration has 4 standard inside width cabinet installation sizes.

- a. 21.9" or 556 mm 1
- b. 33.6" - 33.8" or 854 - 858 mm 3
- c. 37.6" - 37.7" or 954 - 958 mm 3
- d. 45.4" - 45.6" or 1154 - 1158 mm 3

Custom sized cabinets

- e. cut the profile on one side, 0.16" (4 mm) shorter than the internal cabinet width. 3

Required beams per support bar

Step 3: Measure equal distances on both ends for the correct setup.

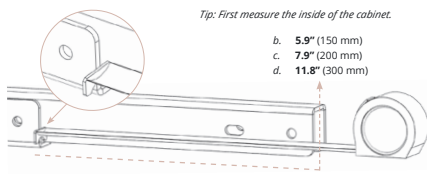

Step 7: Determine the bracket depth.

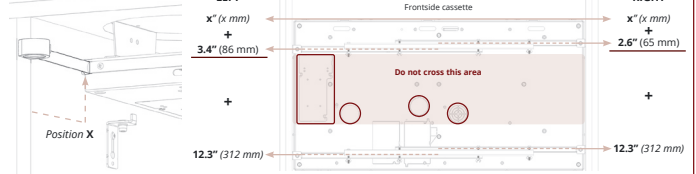

Step 4: Locate the aligning holes and insert two bolts per side through both frames; hand-tighten using the wing nuts.

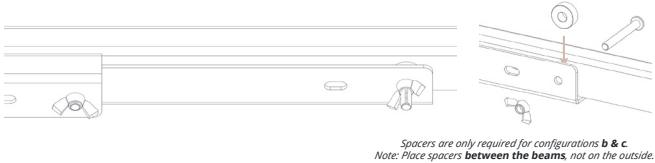

Step 5: Repeat this process. Two complete bridging support sets are required for a secure assembly.

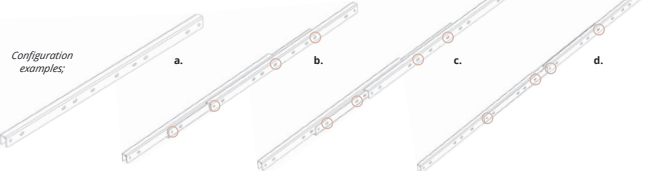

Step 8: Positioning the support beam.

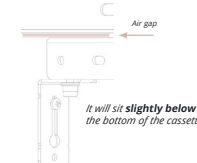

Step 9: Press firmly against cassette.

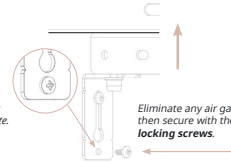

Step 10: Fit the adjustment setscrew.

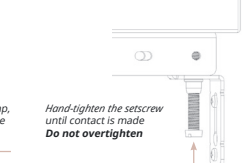

Step 11: Repeat this process on the other side. You have now successfully completed the installation.

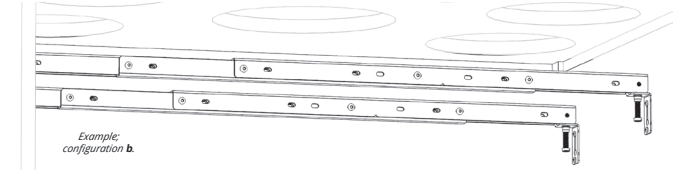

8. Final Steps & checks

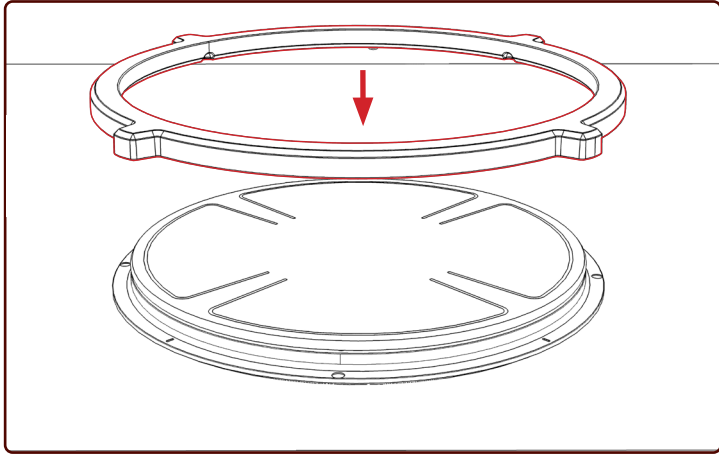

Step 23

Install the decorative ring(s) on the induction zone(s). Make sure the rubber feet fall inside the four holes of the induction zone.

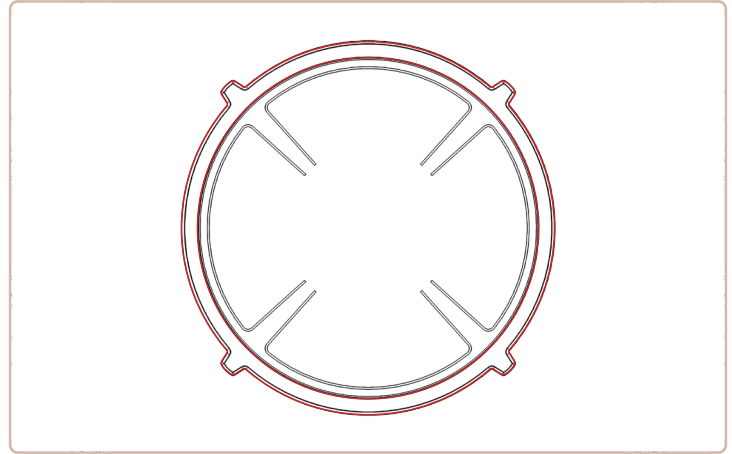

Check

Make sure that the decorative ring is placed in the illustration, like an 'X'.

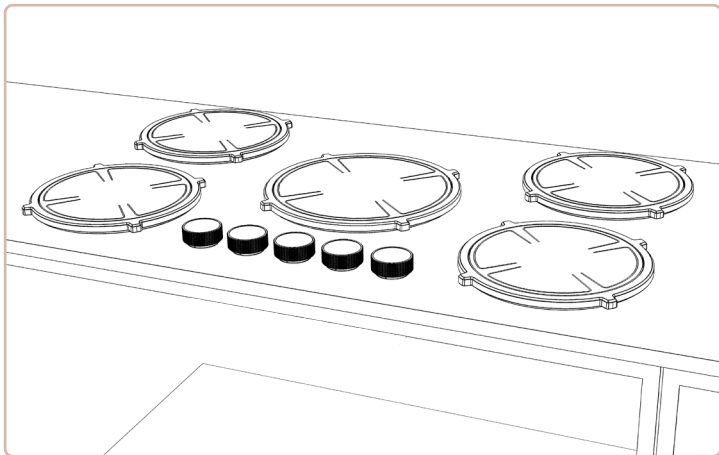

Finished

The installation has now been completed. The image shows an example model of the Top Side.
Make sure to test every induction zone
See the instructions below.

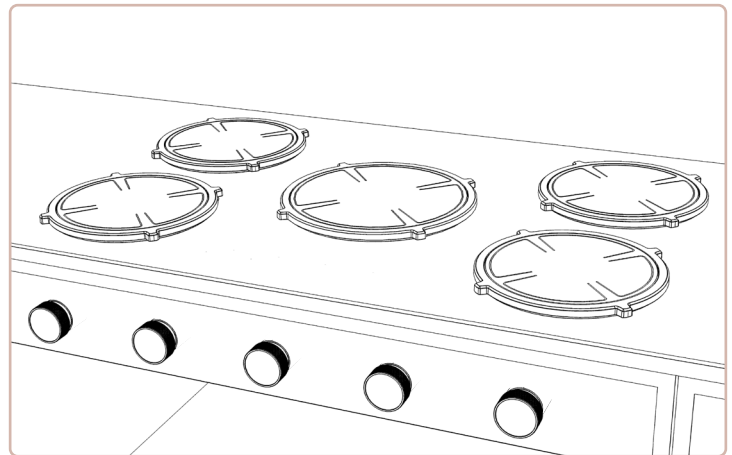

Finished

The installation has now been completed. The image shows an example model of the Front Side.
Make sure to test every induction zone.
See the instructions below.

After installation and checking, test every induction zone with a recommended and suitable induction pan and put the power level on 5. If you can hear a humming noise from the induction zone and pan, the induction zone is working. If this is not the case, contact our service department (see the last page)

Made in Holland

Important

Save this manual for the local electrical inspector's use

PITT Cooking
Damzigt 54
3454 PS De Meern
The Netherlands

T: +31 (0)88 088 70 70
www.pittcooking.com

